

ZONE	SYMBOL	REVISION	APPROVAL	DATE
D3		MODIFY SPECIFICATIONS	S.T.CHU	12-3-2004

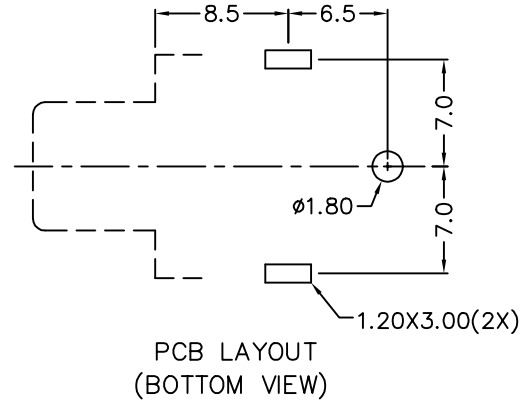

SPECIFICATIONS

1. MAXIMUM INITIAL INSERTION FORCE USING A 3.25mm DIA. GAGE PIN WITH 1.57mm RADIUS SHALL NOT EXCEED 12 POUNDS.
2. CONTACT MUST MAINTAIN 2 OZ. RETENTIONS ON A 3.14mm DIA. GAGE PIN AFTER 50 INSERTIONS OF A 3.25mm DIA. GAGE PIN, 10.16mm LONG.
3. SOLDER LUG TO HAVE SOLDER BARRIER & HEAT BARRIER HOLDES AS INDICATED TO EFFECTIVELY PREVENT THE FLOW OF SOLDER ONTO THE PIN AREA. WHEN SOLDERED, THE BARRIER MUST LIMIT THE FLOW OF SOLDER & ALLOW INSERTION OF A 3.18mm DIA. GAGE PIN TO A DEPTH OF 12.7mm WITHOUT INTERFERENCE.
4. INSULATION RESISTANCE: AT DC 500V MUST BE 50 MEGOHMS MIN.
5. DIELECTRIC STRENGTH: MUST WITHSTAND 500 V RMS FOR ONE MINUTE.

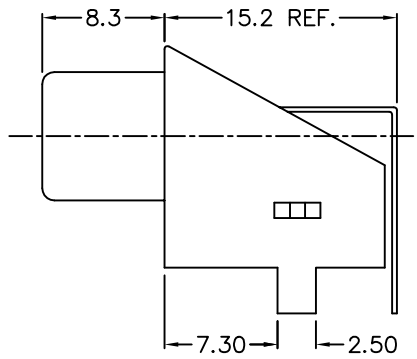
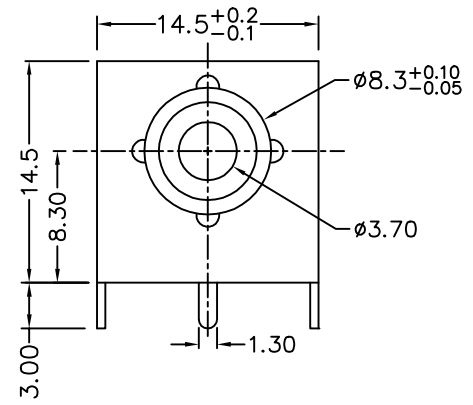

DESIGN		T.Y.LI	DATE	12-3-2004	SCALE	2:1	
DRAWING		T.Y.LI	DATE	12-3-2004	MATERIAL		
PART NAME	RCA SOCKET	TOLERANCE UNLESS	0.0±0.2	CHECK	DATE	DWG. NO.	TZ\RC001/B
PART NO.	TRC-001	OTHERWISE SPECIFIED:	0.00±0.1 0.000±0.05	APPROVAL	DATE	SHEET	