

C		B		A	
ZONE	SYMBOL	REVISION	DWG. NO. TO REVISE	APPROVAL	DATE
				S.T.CHU	8-10-2003

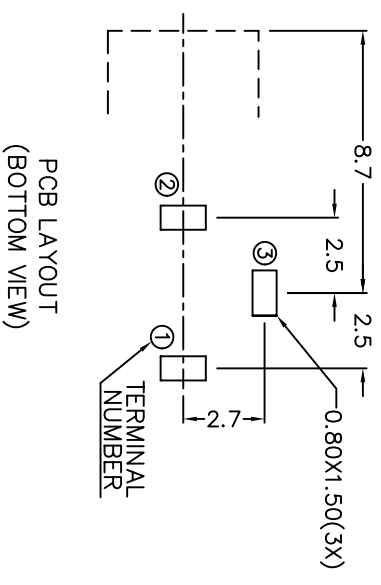
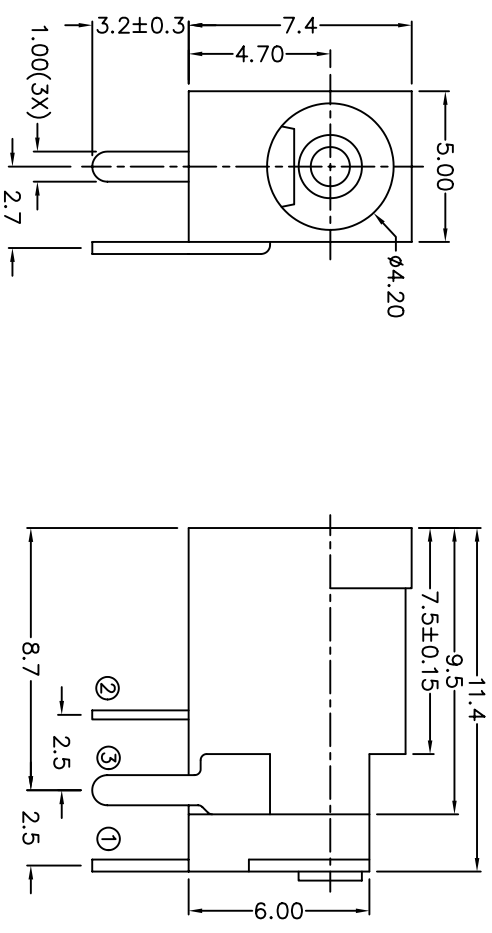

MODEL NO.	TDC-009-1
SCHEMATIC	
CENTER PIN	∅0.7mm
	∅1mm
	∅1.3mm
	∅1.65mm

* MATERIAL
 CENTRE PIN : COPPER
 TERMINAL 1 : BRASS
 TERMINAL 2 : COPPER ALLOY
 TERMINAL 3 : BRASS
 HOUSING : PBT
 COVER : PBT

SPECIFICATIONS

- 1 Insulation resistance of adjacent open terminals shall not be less than 50 Megohms when measured with 500 Volts resistance meter.
- 2 Connector shall withstand 500 Volts (RMS) between adjacent open terminal for one minute.
- 3 Contact resistance of normally closed terminals shall not exceed 0.03 ohms when measured at a current of one Ampere by Voltage drop method.
- 4 Connector shall withstand 5,000 cycles of insertions and withdrawal with testing plug, contact resistance shall not exceed 0.1 ohm.

JOYNET Enterprise Co., Ltd.
 * Technology
 * Profession
 * Service

PART NAME	DC POWER SOCKET	TOLERANCE UNLESS	0.0±0.2	UNIT:	mm	DESIGN	J.X.KUANG	DATE	8-10-2003	SCALE	4:1
PART NO.	TDC-009-1	OTHERWISE SPECIFIED:	0.00±0.1			CHECK	J.X.KUANG	DATE	8-10-2003	MATERIAL	*
			0.000±0.05			APPROVAL		DATE		DWG. NO.	TZ\DC009-1-PBT
								DATE		SHEET	

F E D C B A DGF-04/A